

# AB5632B

Audio Player Microcontroller

Versions: 0.0.6  
2023.02.21



## Declaration

Copyright © 2021, [www.bluetrum.com](http://www.bluetrum.com).

All Rights Reserved. No Unauthorized Distribution.

Bluetrum reserves the right to make changes without further notice to any products herein to improve reliability, function or design.

For further information on the technology, product and business term, please contact Bluetrum Company.

For sales or technical support, please send email to the address:

Sales: [sales@bluetrum.com](mailto:sales@bluetrum.com)

Technical: [project@bluetrum.com](mailto:project@bluetrum.com)

## Revision History

Date	Version	Comments	Revised by
2021-10-25	0.0.1	First draft	Leo
2022-03-15	0.0.2	Modify the information of Product Features	Leo
2022-05-10	0.0.3	Delete BT RADIO support TWS related content, update the supported protocol	Leo
2022-08-31	0.0.4	Update QDID	Leo
2023-01-05	0.0.5	Update Product Features	Leo
2023-02-21	0.0.6	Modify the number of MIC channel	Leo

# Table of Contents

TABLE OF CONTENTS .....	2
<b>1 PRODUCT FEATURES.....</b>	<b>3</b>
<b>2 PACKAGE DEFINITION.....</b>	<b>4</b>
2.1 PIN ASSIGNMENT .....	4
2.2 PIN DESCRIPTIONS .....	5
<b>3 CHARACTERISTICS.....</b>	<b>9</b>
3.1 PMU PARAMETERS .....	9
3.2 IO PARAMETERS .....	9
3.3 AUDIO DAC PARAMETERS.....	10
3.4 AUDIO ADC PARAMETERS.....	11
3.5 BT PARAMETERS.....	11
3.6 CURRENT PARAMETERS.....	11
<b>4 PACKAGE INFORMATION.....</b>	<b>12</b>

## 1 Product Features

### CPU and Flexible IO

- High performance 32bit RISC-V processor Core with DSP instruction
- RISC-V typical speed: 125MHz
- Program memory: internal 4M bit flash
- Internal 256KB RAM for data and program
- Flexible GPIO pins with Programmable pull-up and pull-down resistors;
- Support GPIO wakeup or interrupt;

### Bluetooth Radio

- Compliant to Bluetooth 5.3 and BLE specification (QDID: 193597);
- TX output power MAX +9dBm;
- RX Sensitivity with -94dBm @2M EDR;

### Audio Interface

- High performance stereo DAC with 98dB SNR, support single end mode or differential mode;
- Two channels high performance ADC with 90dB SNR;
- One channel MIC amplifier input;
- Support flexible audio EQ adjust;
- Support Sample rate 8, 11.025, 12, 16, 22.05, 32, 44.1 and 48KHz;
- Four channels Stereo Analog MUX;

### Peripheral and Interfaces

- Support AAC, mSBC high quality decode;
- Support Low power Touch Key;
- Support Low power enter ear detect;
- Three 32-bit timers;
- Three multi-function 32-bit timers, support Capture and PWM mode;
- WatchDog;
- Three full-duplex UART;
- Two SPI;
- IR controller;
- SD Card Host controller;
- Audio interface IIS Master/Slave;
- Full speed USB 2.0 HOST/DEVICE controller;
- Sixteen Channels 10-bit SARADC;
- Integrate IRTC;
- Build in PMU, such as charger/buck/LDO;

### Package

- QFN32L;

### Temperature

- Operating temperature: -40°C to +85°C;
- Storage temperature: -65°C to +150°C;

### Supports

- A2DP/AVDTP/AVRCP/RFCOMM/HFP/HSP/SPP/HID

2 Package Definition

2.1 Pin Assignment

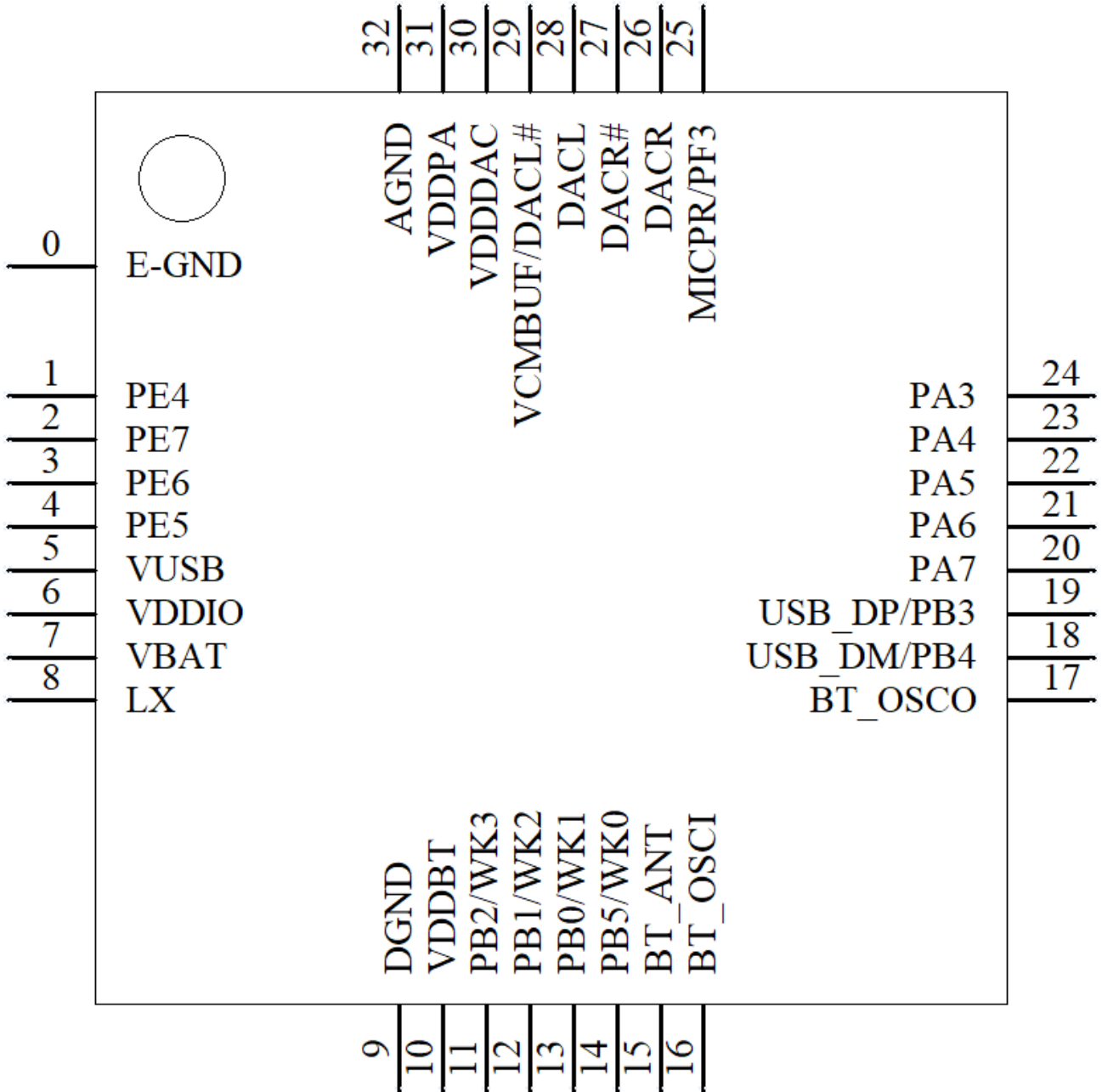

## 2.2 Pin Descriptions

**Table 2-1 QFN32L pin description**

Pin No.	Name	Type	Function
0	E-GND	GND	E-Pad Ground
1	PE4	I/O	SD PG PWM1-T3-G4 PE4
2	PE7	I/O	ADC9 AUXR2 PDM_DATLR-G2 SDDAT0-G3 SPI1DO-G4 TX0-G4 HSTRX-G4 PWM2-T4-G1 IISDO-G2 IISDO-G3 IIC_DAT-G5 TMR4CAP_G1/IR_G8 PE7
3	PE6	I/O	ADC8 AUXL2 PDM_CLKLR-G2 SDCLK-G3 SPI1CLK-G4 RX0-G4 HSTRX-G9 FMOSC-G6 PWM1-T4-G1 IISLRCLK-G2 IISLRCLK-G3 IIC_CLK-G5 IIC_CLK-G6 TMR3CAP_G7/IR_G7 PE6
4	PE5	I/O	ADC7 SDCMD-G3 SPI1DI-G4 FMOSC-G5 PWM0-T4-G1 IISCLK-G2 IIC_DAT-G6 TMR3CAP_G6/IR_G6 PE5
5	VUSB	PWR	VUSB power input TX0-G8 TX1-G3

			TX2-G3 HSTRX-G11
6	VDDIO	PWR	VDDIO power output
7	VBAT	PWR	VBAT power input
8	LX	PWR	Buck inductor connect pin
9	DGND	GND	Digital Ground
10	VDDBT	PWR	BT power
11	PB2/WK3	I/O	ADC4 AUXR1 SDDAT0-G2 SPI1DO-G3 TX0-G2 TX2-G2 HSTRX-G2 PWM2-T3-G1 IISCLK-G3 IISDI-G2 IIC_DAT-G3 WK3 PB2
12	PB1/WK2	I/O	ADC3 AUXL1 SDCLK-G2 SPI1CLK-G3 RX0-G2 RX2-G2 HSTRX-G7 FMOSC-G4 PWM1-T3-G1 IISMCLK-G3 IISMCLK-G2 IIC_CLK-G3 IIC_CLK-G4 TMR3CAP_G4/IR_G4 WK2 PB1
13	PB0/WK1	I/O	WK1 ADC11 SDCMD-G2 SPI1DI-G3 FMOSC-G3 PWM0-T3-G1 IIC_DAT-G4 TMR3CAP_G3/IR_G3 PB0
14	PB5/WK0	I/O	WK0 ADC12 PWM2-T3-G2 IISDI-G3 WK0 PB5

15	BT_ANT	A	BT ANT
16	BT_OSCI	A	24M OSC input
17	BT_OSCO	A	24M OSC output
18	PB4/USB_DM	I/O	ADC6 USB DM PDM_DATLR-G4 SDDAT0-G4 SDDAT0-G6 SPIOCLK-G3 RX0-G3 HSTRX-G8 PWM1-T3-G2 IIC_DAT-G8 PB4
19	PB3/USB_DP	I/O	ADC5 USB DP PDM_CLKLR-G4 SDDAT0-G5 SDCMD-G6 SPIO0-G3 TX0-G3 HSTRX-G3 PWM0-T3-G2 IIC_CLK-G8 PB3
20	PA7	I/O	ADC2 AUXR0 PDM DATLR-G3 SDDAT0-G1/G7 SPI1DO-G2 TX0-G1 TX1-G1 HSTRX-G1 PWM2-T5-G1 IISDO -G1 IIC_DAT-G1 PA7
21	PA6	I/O	ADC1 AUXL0 PDM_CLKLR-G3 SDCLK-G1/G4/G5/G6 SPI1CLK-G2 RX0-G1 RX1-G1 HSTRX-G6 FMOSC-G2 PWM1-T5-G1 IISLRCLK-G1 IIC_CLK-G1/G2 TMR3CAP_G2/IR_G2 PA6
22	PA5	I/O	ADC0



			SDCMD-G1/G4/G5 SPI1DI-G1/SPI1DI-G2 FMOSC-G1 PWM0-T5-G1 IISCLK-G1 IIC_DAT-G2 TMR3CAP_G1/IR_G1 PA5
23	PA4	I/O	SPI1DO-G1 TX1-G2 PWM2-T3-G3 IISMCLK-G1 PA4
24	PA3	I/O	SPI1CLK-G1 RX1-G2 PWM1-T3-G3 IISDI-G1 PA3
25	MICPR/PF3	I/O	MICPR PWM2-T4-G2 PF3
26	DACR	A	DAC R
27	DACR#	A	DAC differential R#
28	DACL	A	DAC L
29	DACL#/VCMBUF	A	DAC differential L# VCM buffer output
30	VDDDAC	PWR	DAC power
31	VDDPA	PWR	DAC 1.2V power
32	AGND	GND	DAC Ground

Note: I/O: Digital input/output; I : Digital input; A : Analog Pin; PWR: Power Pin; GND: Ground.

## 3 Characteristics

### 3.1 PMU Parameters

Table 3-1 PMU voltage input Parameters

Sym	Characteristics	Min	Typ	Max	Unit	Conditions
VUSB	Charger Voltage input	4.6	5.0	5.5	V	
VBAT	Voltage input	3.0	3.7	4.5	V	

Table 3-2 3.3V LDO Parameters

Sym	Characteristics	Min	Typ	Max	Unit	Conditions
VDDIO	3.3V LDO voltage output	-	3.3	-	V	Light Loading condition
$\Delta$ VDDIO	Output Mismatch 1-sigma	-	43	-	mV	VDDIO=3.3v
ILOAD	Maximum output current	-	-	150	mA	@VBAT=3.6v
ISC	Short Circuit Current Limit	-	-	300	mA	@VBAT=3.8v

Table 3-3 1.2V LDO Parameters

Sym	Characteristics	Min	Typ	Max	Unit	Conditions
VDDBT	1.2V LDO voltage output	-	1.2	-	V	Light Loading condition
$\Delta$ VDDBT	Output Mismatch 1-sigma	-	16	-	mV	VDDBT=1.2v
ILOAD	Maximum output current	-	-	100	mA	@VBAT=3.0v
ISC	Short Circuit Current Limit	-	-	200	mA	@VBAT=3.8v

Table 3-4 1.1V LDO Parameters

Sym	Characteristics	Min	Typ	Max	Unit	Conditions
VDDCORE	1.1V LDO voltage output	-	1.1	-	V	Light Loading condition
$\Delta$ VDDCORE	Output Mismatch 1-sigma	-	15	-	mV	VDDCORE=1.1v
ILOAD	Maximum output current	-	-	60	mA	@VBAT=3.6v
ISC	Short Circuit Current Limit	-	-	120	mA	@VBAT=3.8v

### 3.2 IO Parameters

Table 3-5 I/O Parameters

GPIO—Electrical Characteristics							
Symbol	Description	Related GPIO	Min	Typical	Max	Units	Conditions
$V_{IL}$	Low-level input voltage		-0.3		1.27	V	VDDIO=3.3V
$V_{IH}$	High-level input voltage		2.03		3.6	V	VDDIO=3.3V
Driver Ability 1	Output Driver Ability 1			32		mA	VDDIO=3.3V
Driver Ability 0	Output Driver Ability 0			8		mA	VDDIO=3.3V
$R_{PUP0}$	Internal pull-up resistor 0		8	10	12	K $\Omega$	
$R_{PUP1}$	Internal pull-up resistor 1		0.24	0.3	0.36	K $\Omega$	
$R_{PUP2}$	Internal pull-up resistor 2		160	200	240	K $\Omega$	

GPIO—Electrical Characteristics							
R <sub>PDN0</sub>	Internal pull-down resistor 0		8	10	12	KΩ	
R <sub>PDN1</sub>	Internal pull-down resistor 1		0.24	0.3	0.36	KΩ	
R <sub>PDN2</sub>	Internal pull-down resistor 2		160	200	240	KΩ	

### 3.3 Audio DAC Parameters

Table 3-6 Audio DAC Parameters

Mode	Sym	Characteristics	Min	Typ	Max	Unit	Conditions
Differential Mode	SNR		-	98.8	-	dB	VCM cap=NC VDDDAC cap=1uF with A-wt filter Output -4.2dBV with 10K loading Fin=1KHz
	THD+N		-	-73	-	dB	VCM cap=NC VDDDAC cap=1uF with A-wt filter Output -4.2dBV with 10K loading Fin=1KHz
	Output Range	Maximum output voltage	-	-4.2		dBVrms	32ohm Loading
VCMBUF Mode	SNR			96		dB	VCM cap=NC VDDDAC cap=1uF with A-wt filter Output -1.1dBV with 10K loading Fin=1KHz
	THD+N			-73		dB	VCM cap=NC VDDDAC cap=1uF with A-wt filter Output -1.1dBV with 10K loading Fin=1KHz
	Output Range	Maximum output voltage		-1.1		dBVrms	32ohm Loading
AC Coupling Mode	SNR			95		dB	VCM cap=NC VDDDAC cap=1uF with A-wt filter Output -1.1dBV with 10K loading@220uF AC coupling Cap Fin=1KHz
	THD+N			-73		dB	VCM cap=NC VDDDAC cap=1uF with A-wt filter Output -1.1dBV with 10K loading@220uF AC coupling Cap

Mode	Sym	Characteristics	Min	Typ	Max	Unit	Conditions
							Fin=1KHz
	Output Range	Maximum output voltage		-1.1		dBVrms	32ohm Loading

### 3.4 Audio ADC Parameters

Table 3-7 Audio ADC Parameters

Sym	Characteristics	Min	Typ	Max	Unit	Conditions
SNR		-	90	-	dB	VCM cap=NC VDDDAC cap=1uF with A-wt filter Input sine amplitude, 850mV RMS Fin=1KHz
THD+N		-	-	-	dB	VCM cap=NC VDDDAC cap=1uF with A-wt filter Input sine amplitude, 850mV RMS Fin=1KHz.
Input Range	Input sine wave peak amplitude	VCM-1.2	-	VCM+1.2	V	From aux input, aux 0db gain, VCM represent VCM voltage.

### 3.5 BT Parameters

Table 3-8 BT Parameters

Characteristics	Min	Typical	Max	Unit	Conditions
Transmit Power	-	8	9	dBm	Maximum TX power 2-DH5 packet
RMS DEVM	-	5.5	-	%	
Peak DEVM	-	12.5		%	
EDR Relative Transmit Power		-0.2		dB	
Sensitivity @ Basic Rate		-91.8		dBm	BER=0.1%, using DH5 packet
Sensitivity @ EDR		-94		dBm	BER=0.01%, using 2-DH5 packet

### 3.6 Current Parameters

Table 3-9 Current Parameters

Sym	Characteristics	Min	Typ	Max	Unit	Conditions
IRTC	RTC mode current	-	4	-	uA	4.2V input, room temp.
Sleep	Sleep current	-	500	2000	uA	3.3V input, room temp

**4 Package Information**

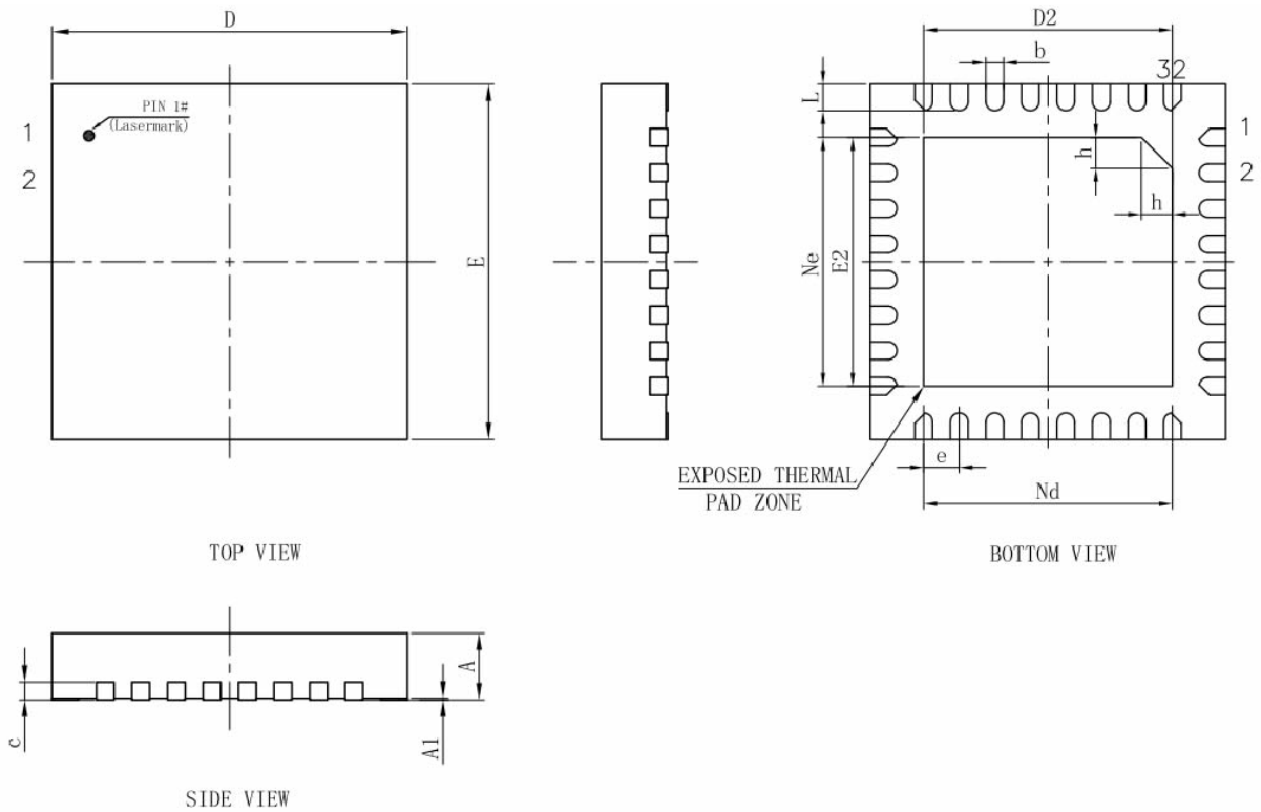

SYMBOL	MILLIMETER		
	MIN	NOM	MAX
A	0.70	0.75	0.80
A1	0	0.02	0.05
b	0.15	0.20	0.25
c	0.18	0.20	0.25
D	3.90	4.00	4.10
D2	2.70	2.80	2.90
e	0.40BSC		
Ne	2.80BSC		
Nd	2.80BSC		
E	3.90	4.00	4.10
E2	2.70	2.80	2.90
L	0.25	0.30	0.35
h	0.30	0.35	0.40
L/F载体尺寸	122X122		



## Contact us

Address: 深圳市南山区沙河街道高发社区侨香路 4068 号智慧广场 A 栋  
1301-1

E-mail: [info@bluetrum.com](mailto:info@bluetrum.com)

Website: [www.bluetrum.com](http://www.bluetrum.com)